

Centrifugal pumps

Model C2G

Sectional Drawing

Description

Vertical in-line pumps with overhung single suction impeller, radially split with rigid coupling. Comes with ball bearings and mechanical seal as an integral unit which enables a very quick maintenance turnaround time.

Capacity: 30-1600 m³/h

Differential pressure: 15-150 mlc.

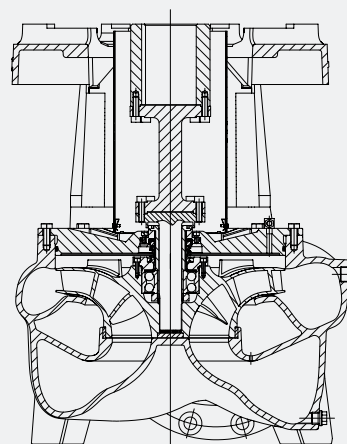

Spacer coupled dimensions

Low pressure	Pump Size	Flange According To ISO 7005 PN10 or JIS B2210-10K		Dimensions (mm)				Weight* (kg)
		Discharge flange ND	Suction flange ND	A	B	C	D	
	C2G - 50L	50	65	360	100	395	236	41
C2G - 65L	65	80	360	107	402	248	44	
C2G - 80L	80	100	360	115	410	259	45	
C2G - 100L	100	125	400	130	435	295	56	
C2G - 125L	125	150	500	147	565	455	130	
C2G - 150L	150	200	560	175	608	498	155	
C2G - 200L	200	250	630	206	692	545	250	
C2G - 250L	250	300	710	240	750	630	325	
C2G - 300L	300	350	1060	270	998	811	563	
C2G - 400L	400	500	1200	350	1148	989	703	

Medium pressure	Pump Size	Flange According To ISO 7005 PN10 or JIS B2210-10K		Dimensions (mm)				Weight* (kg)
		Discharge flange ND	Suction flange ND	A	B	C	D	
	C2G - 100M	100	125	450	130	496	398	83
C2G - 125M	125	150	680	147	606	527	189	
C2G - 150M	150	200	700	175	634	557	217	
C2G - 200M	200	250	710	205	730	577	329	
C2G - 250M	250	300	800	230	757	669	346	
C2G - 300M	300	350	1200	270	1049	894	585	
C2G - 400M	400	500	1320	350	1199	993	755	

High pressure	Pump Size	Flange According To ISO 7005 PN10 or JIS B2210-10K		Dimensions (mm)				Weight* (kg)
		Discharge flange ND	Suction flange ND	A	B	C	D	
	C2G - 65H	65	80	500	105	481	477	121
C2G - 80H	80	100	500	115	496	477	126	
C2G - 100H	100	125	500	150	619	660	126	
C2G - 125H	125	150	500	170	640	660	209	
C2G - 150H	150	200	560	195	684	660	231	
C2G - 200H	200	250	630	228	724	660	258	

*Approximate Weight (excluding motor)

Closer coupled dimensions

Pump Size	Discharge flange ND	Suction flange ND	C1 (mm)	Weight* (kg)
C2G - 50L	50	60	246	33
C2G - 65L	65	80	253	36
C2G - 80L	80	100	261	38
C2G - 100L	100	125	286	47
C2G - 125L	125	150	333	104
C2G - 150L	150	200	375	129
C2G - 200L	200	250	429	157

Close Coupled

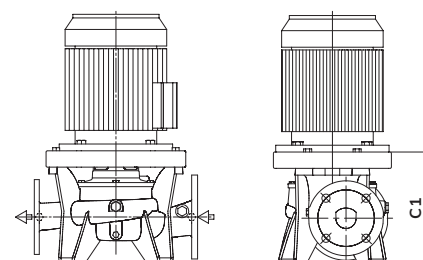

Spacer Coupled

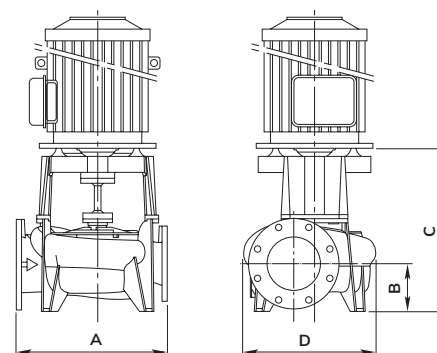

Construction code

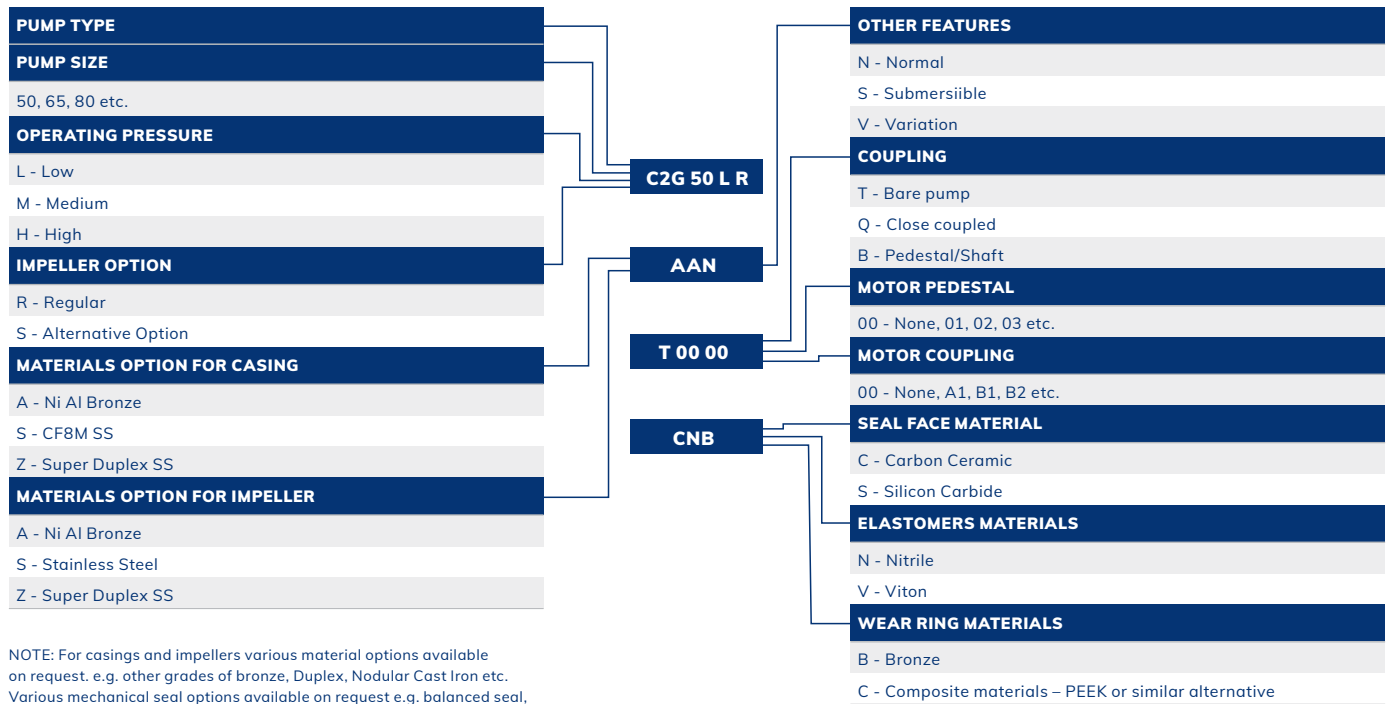

NOTE: For casings and impellers various material options available on request. e.g. other grades of bronze, Duplex, Nodular Cast Iron etc. Various mechanical seal options available on request e.g. balanced seal, hard seal faces etc. For elastomers materials other options available on request e.g. EPDM.

Capacity range

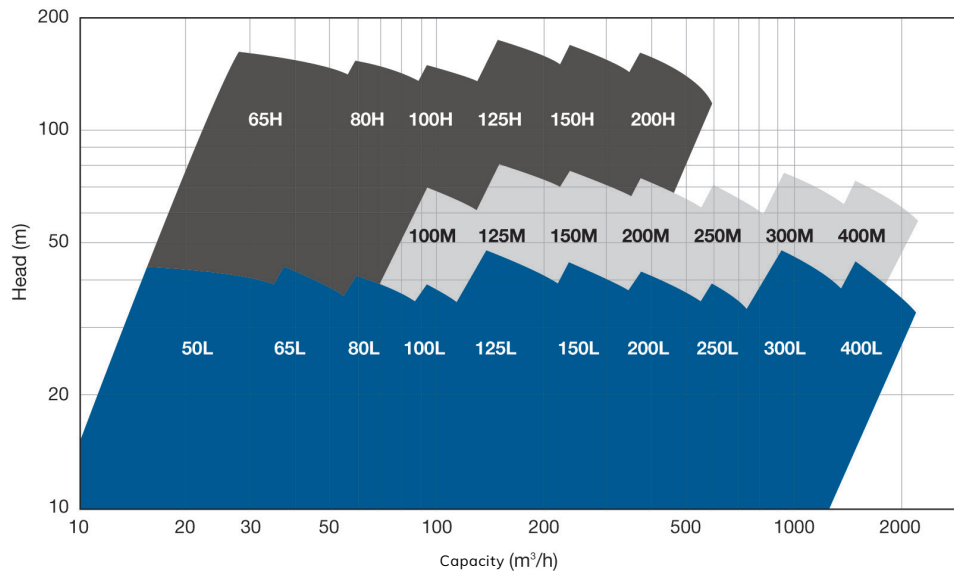

The manufacturers reserve the right to alter the specification and data to incorporate improvements in design. Certified drawings will be issued on request.

© All details copyright Hamworthy Pumps

Website: www.hamworthy-pumps.com

 **Hamworthy Pumps**

Hamworthy Pumps Singapore Pte Ltd
 Tel: +65 6261 6066
 Email: sgpumpsales@hamworthy-pumps.com

Hamworthy Pumps UK Ltd
 Tel: +44 (0) 788 6851102
 Email: gbpumps@hamworthy-pumps.com